

Below-Hook Drum Karriers

- Transport a Loaded Drum with your Hoist or Crane
- Fast Manual Drum Dispensing or Dumping

Morse Drum Karriers are made in several sizes for various drums (see chart below). They are built with welded structural steel for long service. A tilt lock is provided at each side of the hanger frame. Either tilt lock may be used to secure the drum in upright or horizontal position for added convenience. When they are unlocked, the drum may be manually tilted to any angle for discharging contents. The drum can also be rotated 360° in either direction.

Capacity: 800 Lb. (363 kg) Full drum, 500 Lb. (227 kg) Half-Full drum.
Each unit is shipped fully assembled in a durable carton. Shipping weight is 41 Lb. (18.6 kg). It can be shipped by UPS, RPS or by truck (class 77.5).

Custom versions are also available for other sizes and types of drums.

Options and Accessories

The **Bracket Assembly** fits model 85i to provide a brace at top and bottom of your drum, preventing it from slipping lengthways through the drum holder. The Bracket Assembly is required to handle a 55-gallon plastic drum and recommended to more securely handle a fiber drum. It adjusts for a 31" to 39" (78.7 to 99 cm) tall drum.

Part # 4556-P Bracket Assembly Option.



Model 85i



Model 85i with Bracket Assembly Option (part # 4556-P) installed



Diameter Adaptors (see chart on side 2) are available to insert into the drum holder of model 85i or 85i-SS for handling various smaller drums. Select the correct size Diameter Adaptor for each drum. Adaptors for a 18.5" (47 cm) diameter or larger can be used in combination with the Bracket Assembly.

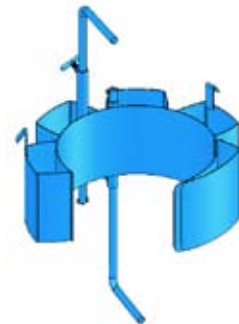

Diameter Adaptors for a drum with 17.5" (44.5 cm) diameter or smaller have integrated end brackets which adjust for a drum up to 38" (96.5 cm) tall.

Spark resistant and stainless steel Diameter Adaptors are also available (chart side 2).



Model 85i-SS

85 Series Drum Karriers with 800 Lb. Capacity

Model #	Description	For Drum Size / Type	Ship Weight
85i	Below-Hook Drum Karrier	55-Gallon (208 liter) steel drum. • Accepts Bracket Assembly for fiber or plastic drum. • Accepts Diameter Adaptors for smaller drum.	43 Lb. (19.5 kg)
85i-SS	Below-Hook Drum Karrier made of type 304 stainless steel	55-Gallon (208 liter) steel drum. • Accepts Diameter Adaptors for smaller drum.	41 Lb. (18.6 kg)
85A	Below-Hook Drum Karrier	55-Gallon (208 liter) steel drum	41 Lb.
85AM	Below-Hook Drum Karrier with spark resistant parts	55-Gallon (208 liter) steel drum	41 Lb.
85C	Below-Hook Drum Karrier	21" to 23" (53.3 to 58.4 cm) Diameter steel drum	41 Lb.
85G	Below-Hook Drum Karrier with 3-Piece drum holder	55-Gallon (208 liter) steel drum	55 Lb. (25 kg)

How to Use Below-Hook Drum Karriers



Model 85A shown

The suspended Drum-Karrier is pushed against the drum so that the drum holder is positioned to engage between the drum ribs.

Tighten the cinch chain around your drum to secure it in the drum holder. No tools are required to apply suitable tension to secure the drum. Raise your hoist and move the drum to a location for dispensing.

Pull out the tilt locks and tip the drum to dispense its contents. The drum can be turned 360° in either direction, and locked at either horizontal or vertical position.

Dimensions

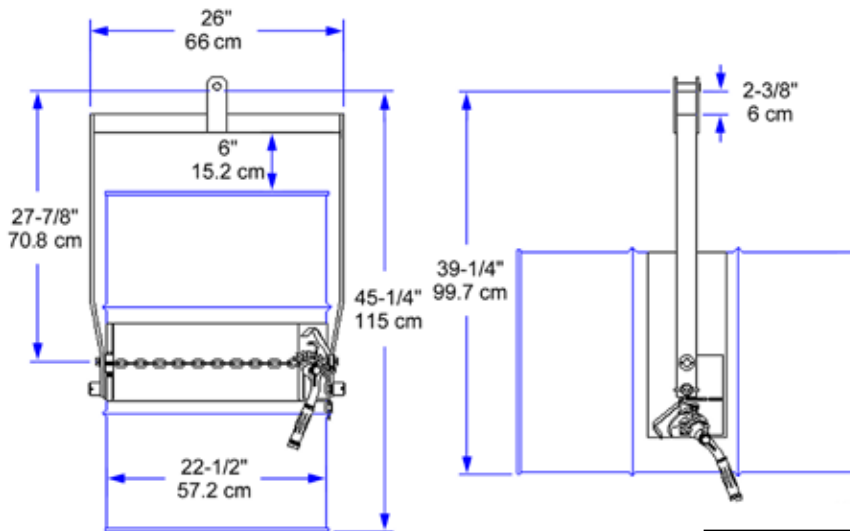

High Strength Lifting Components and Improved Drum Holder

Morse Below-Hook Drum Karriers use high strength lifting components as specified by OSHA for overhead lifting.

With the exception of model 85G (see below), your drum is secured by high strength, wear resistant chain manufactured to Morse specifications. The chain tightening ratchet and spring loaded pawl assembly has been redesigned with stronger teeth and redundant safety features for reliability and ease of use.



Model 85i has a flexible chain cover over the cinch chain to help protect the sidewall of your drum. The drum holder on model 85i is improved to accept the Bracket Assembly and Diameter Adaptors (shown on side 1), which enable you to handle a variety of drums.



Model 85G has the 3-Piece Drum Holder designed specifically for a 55-gallon steel drum only. The 8" wide metal band is hinged on the sides and has a toggle clamp secure your drum in the holder.

Please contact your Morse dealer

Diameter Adaptors Fit Models 85i and 85i-SS

Diameter Adaptors	Spark Resistant Diameter Adaptors	Stainless Steel Diameter Adaptors	Fits Diameters	Ship Weight
55/30-22	55/30M-22	55/30SS-22	21.5" to 22"	11 Lb.
55/30-20.5	55/30M-20.5	55/30SS-20.5	20" to 20.5"	23 Lb.
55/30-19	55/30M-19	55/30SS-19	18.5" to 19"	24 Lb.
55/30-17.5	55/30M-17.5	55/30SS-17.5	17" to 17.5"	35 Lb.
55/30-16	55/30M-16	55/30SS-16	15.5" to 16"	35 Lb.
55/30-14.5	55/30M-14.5	55/30SS-14.5	14" to 14.5"	36 Lb.