

Drum Movers and Palletizers

Video at www.MORSEmfgco.com



Model 82H-125 has battery-power drum lift



Models 82H & 82HM have hand pump drum lift. 27 pumps raises the drum to maximum height.



82H Series move and palletize upright drum

- Efficiently move upright drum onto and off pallets and floor
- Handle virtually any rimmed steel, fiber or plastic drum up to 1000 Lb. (454 kg)
- Drums may be tight head or removable top securely clamped in place
- Handle drums of various diameters
- Requires drum at least 28.5" (72.4 cm) tall and 75 Lb. (34 kg) minimum weight to activate jaws
- Raise a 34-7/8" (88.6 cm) tall drum up to 19" (48.3 cm) above the floor
- Models available with ergonomic battery, electric or air power lift
- Completely mechanical automatic drum grip
- Precision mechanism is built to last with wide jaws for secure grip



Grab, lift and move drum in minimum time with this efficient drum handler. Drum gripping jaws in the "head" provide automatic hold to carry your drum in vertical position.

The gripping action is completely mechanical and automatic. With the "head" containing the jaws below the level of the drum rim, simply press Model 82H against the drum, raise the "head" to engage the grip and lift drum. Move your drum to the desired location. The jaws release when drum is set down on floor or pallet. The head can be easily interchanged with drum holder of the 82A Series, to enable dispensing drum.

Jaws grip the upper rim of your plastic, steel or fiber drum weighing up to 1000 Lb. (454 kg).

Models 82HM and 82HM-124 have [spark resistant parts](#), such as the back rest and head with jaws (shown right).



Dimensions

- Overall width: 48.5" (123.2 cm)
- Overall length: 43" (109.2 cm)
- Turning radius: 53" (135 cm)
- Legs are 9" (22.9 cm) high and reach 20.75" (52.7 cm) in front of upright stanchion
- (2) 4" (10.2 cm) swivel casters at back
- (2) 6" (15.2 cm) wheels at front



Install Kit # 4725-P

To convert an 82H Drum Palletizer for moving your upright drum, to an 82A for moving and pouring a drum.

Model #	Drum Holder	Features	Motor Type	Motor Control	Ship Weight
82H	Jaws and brace on sidewall	Hand Pump Lift	-	-	456 Lb.
82H-120	Jaws and brace on sidewall	AC Power Lift	1PH/115V/60Hz, TEFC	Switch, cord and plug	525 Lb.
82H-124	Jaws and brace on sidewall	Air Power Lift	Air Valve	On / Off valve	440 Lb.
82H-125	Jaws and brace on sidewall	Battery Power Lift *	12V DC *	Built-in	512 Lb.
82HM	Jaws and brace on sidewall	spark resistant parts , Hand Pump Lift	-	-	448 Lb.
82HM-124	Jaws and brace on sidewall	spark resistant parts , Air Power Lift	Air Valve	On / Off valve	440 Lb.

* 12V DC Power Lift includes 12V deep cycle battery, and 100/220V 50/60Hz AC charger.

Manual Lift Models

Hand Pump to raise drum.

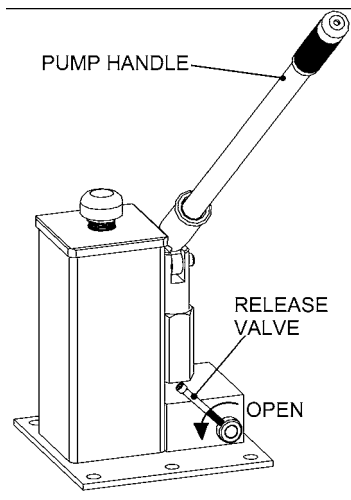

Hand Pump Lift Control
Models 82H and 82HM

It takes 27 pumps of the hand pump to lift a drum to maximum height.

Models with Power Lift

Models with power lift provide a more ergonomic means of raising your drum.

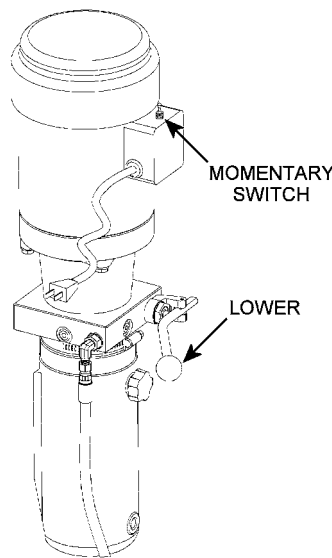

Electric Power Lift Controls
Model 82H-120

Use switch to raise the drum. Lower the drum with manual release valve.

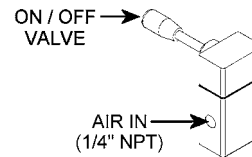

Air Power Lift Controls
Models 82H-124 and 82HM-124

Use on / off valve to raise and lower the drum.

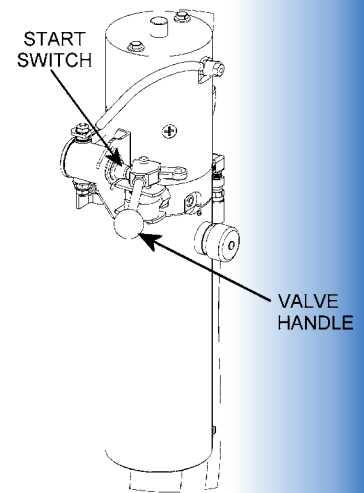

Battery Power Lift Controls
Model 82H-125

Self contained battery power-lift. Use valve to raise and lower the drum. 12V deep cycle battery and separate charger are included.

Please contact your Morse dealer: