

Lift and Dispense a Drum with Your Hoist or Crane

Video at www.MORSEmfgco.com

Kontrol-Karrier - 800 Lb. Capacity

- Attaches to your hoist or crane for quick, sure below-hook drum handling
- Provides controlled high-level pouring above your reach
- Allows 360° drum tilt control in both directions
- Saves time, reduces waste, and improves productivity



Kontrol-Karrier with 3-Piece Drum Holder

- For 22.5" diameter steel drum
- Accepts Diameter Adaptor for 19" diameter drum
- Bolt-on Top Rim Clamp Option
 - Bracket Assembly Option for a plastic or fiber drum

Model 185G

- Has chain wheel controlled tilt with 30:1 gear ratio and safety cover
- Stands upright on foot support
- Handles drum with drum faucet in place
- Has 800 Lb. full-drum capacity (500 Lb. half-full* drum capacity).
- Ship dimensions: L 40" W 10" H 39", by class 77.5
- Ship weight: 85 Lb.



* Half-full rating is an indication of capacity for tilting an unbalanced, bottom-heavy drum. A partially full drum with unbalanced and shifting load is harder to tilt than a full drum.

MADE IN USA

Custom versions available

- Longer arms for use with Drum Cone
- Nested lifting point to reduce required head room
- USDA approved epoxy or "steel-it" paint

Morse Kontrol-Karriers have a 12' long pull chain loop with 6' drop so you control drum tilting, 360° in either direction. Dispense a drum overhead with your crane or hoist. Can also be ordered with Hand Crank or Hand Wheel option for use only within reach of operator.

We recommend the MORStop Tilt-Brake option to automatically hold the drum tilt angle until you move it. This prevents a partially full, unbalanced drum from turning out of control, even when the contents shift from one end to the other.

Options

Diameter Adaptor for Smaller Diameter Drum



This **Diameter Adaptor** allows you to handle a 19" diameter drum with model 185G-HD. Simply place Diameter Adaptor into the drum holder. When you complete dispensing, simply lift the Diameter Adaptor out of the drum holder to return to handling a 55-gallon drum.

Model # 55/30-19GR
Diameter Adaptor for 18.5" to 19" diameter.

MORStop Tilt-Brake prevents unwanted drum tilting



We recommend **Option # 3900i-P** MORStop Tilt-Brake factory installed between the chainwheel and the frame on your Kontrol-Karrier to automatically hold the drum tilt angle.

Part # 3900-P MORStop Tilt-Brake Kit for field installation.

Tilt Control Options Hand Crank or Hand Wheel



Option X01-185 Hand Crank with MORStop Tilt-Brake provides a self-stopping hand crank to prevent drum from tilting out of control.

Option X02-185 Hand Crank.

Option X03-185 16" Hand Wheel.

Counter Weight to keep unit level

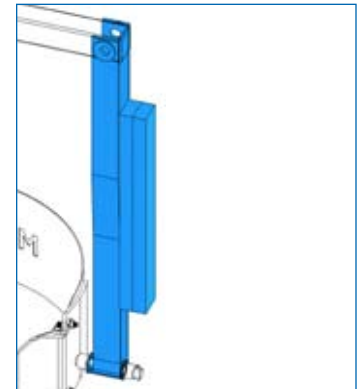

Option 4623-P Counter Weight keeps your Kontrol-Karrier hanging plumb, even without a drum in the holder.

Steps For Use of Model 185G Kontrol-Karrier

1. Start with the Kontrol-Karrier on the floor. Attach lifting point of the Kontrol-Karrier to your hoist hook, then move to your upright drum.
2. Raise your hoist to lift the Kontrol-Karrier. Mate the Kontrol-Karrier's drum holder to the middle of your drum.
3. Secure drum holder to your drum between drum ribs...no tools are needed. To secure drum, pull the linch pin, open the toggle clamp and swing both hinged bands to the open position. Push Kontrol-Karrier against drum so that the drum holder will encircle drum. Close the two hinged bands around the drum, latch the toggle clamp and insert the linch pin.

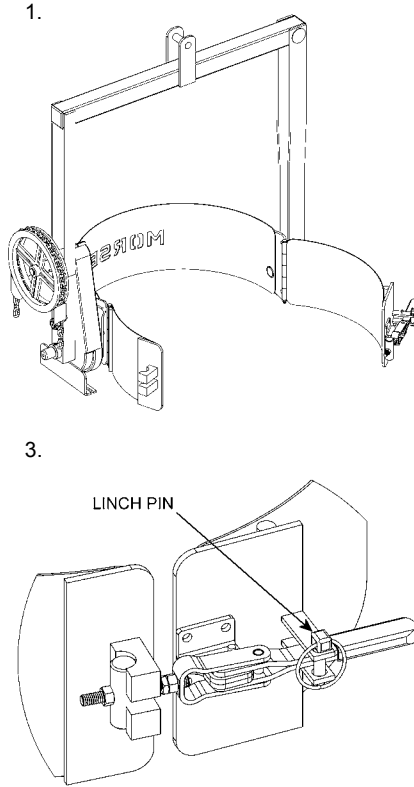

4. Lift the Kontrol-Karrier and secured drum, with your hoist or crane.
5. To control turning of your drum, pull down on one side of the pull chain loop while letting out the other. The chain lock on the bottom of the power arm can be used to prevent drum rotation. To do so, criss cross the chain and insert in each slot of the chain lock.

If your drum handler is equipped with the MORStop Tilt-Brake Option, there is no need to hold tension on the chain loop. Braking is immediate and self actuating. To add the MORStop Tilt-Brake to your drum handler, order part # 3900-P for a field installation kit.

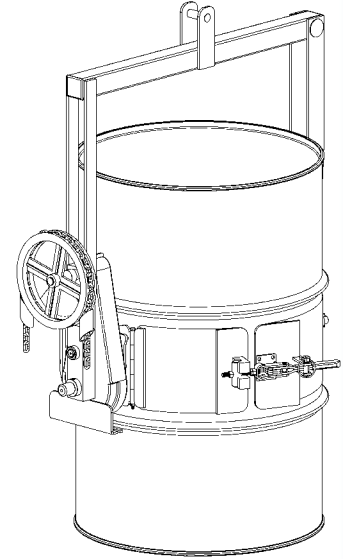

MADE
IN
USA

6. After pouring is completed, rotate drum back to vertical position and lower hoist to return drum to floor.
7. To remove drum from your Kontrol-Karrier, pull the linch pin, open the toggle clamp and swing both hinged bands to the open position.

Dimensions

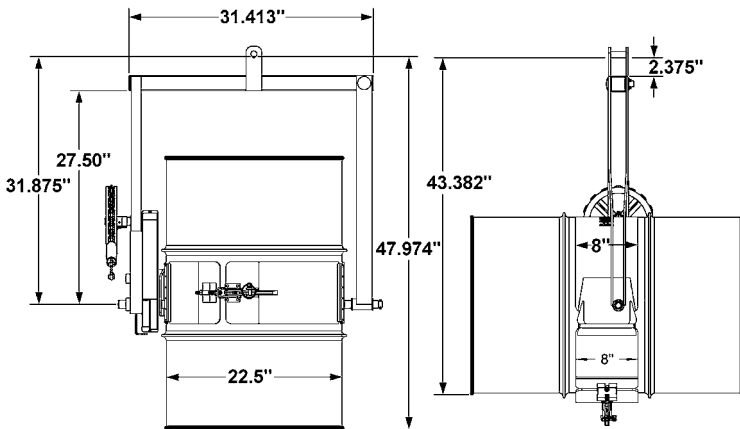

NOTE: Standard loop of pull chain extends approximately six feet below the chain wheel. Custom lengths are available.

Please contact your Morse dealer