

Lift and Dispense a Drum with Your Hoist or Crane

Video at www.MORSEmfgco.com

Kontrol-Karriers - 800 Lb. Capacity

- Attaches to your hoist or crane for quick, sure below-hook drum handling
- Provides controlled high-level pouring above your reach
- Allows 360° drum tilt control in both directions
- Saves time, reduces waste, and improves productivity
- Model 185AM has spark resistant parts
- Custom versions available
- Longer arms for use with Drum Cone
- Nested lifting point to reduce required head room
- USDA approved epoxy or "steel-it" paint

Morse Kontrol-Karriers have a 12' long pull chain loop with 6' drop so you control drum tilting, 360° in either direction. Dispense a drum overhead with your crane or hoist. Can also be ordered with Hand Crank or Hand Wheel option for use only within reach of operator.

We recommend the MORStop Tilt-Brake option to automatically hold the drum tilt angle until you move it. This prevents a partially full, unbalanced drum from turning out of control, even when the contents shift from one end to the other.



NEW MORCINCH™ Drum Handling System

- Automatically adjusts for 22" to 23.5" diameter drum
- Accepts Diameter Adaptors for your smaller drum



• Bolt-on Top Rim Clamp or Bracket Assembly to handle plastic drum or more securely handle fiber drum

- Includes a flexible cover on the cinch chain to help protect the sidewall of your drum
- Incorporates alloy cinch chain and durable stress relief weld joints

Models 185A & 185AM Kontrol-Karriers

- Have chain wheel controlled tilt with 30:1 gear ratio and safety cover
- Stand upright on new foot support
- Handle drum with drum faucet in place
- Have 800 Lb. full-drum capacity (500 Lb. half-full* drum capacity).
- Ship dimensions: L 39" W 39" H 10", class 77.5

* Half-full rating is an indication of capacity for tilting an unbalanced, bottom-heavy drum. A partially full drum with unbalanced and shifting load is harder to tilt than a full drum.

MODEL #	KONTROL-KARRIER DESCRIPTION	OPTIONS TO HANDLE	ADAPTORS FOR SMALLER DRUM	SHIP WEIGHT
185A	Handle 55-gallon steel drum	Poly or fiber drum	55/30 Series	71 Lb.
185AM	Spark Resistant Parts, handle 55-gallon steel drum	Poly or fiber drum	55/30M Series	68 Lb.

MORCINCH Options

Bracket Assembly for rimless poly drum or to more securely handle a fiber drum



The **Bracket Assembly** provides a brace at top and bottom of your drum to prevent it from slipping lengthways through the drum holder. The Bracket Assembly is required to handle a rimless plastic drum, and recommended to more securely handle a fiber drum. It adjusts for 31" to 39" tall drum.

Part # 4556-P Bracket Assembly.

Part # 4556M-P Spark Resistant Bracket Assembly.

Top Rim Clamp for 55-gallon rimmed plastic or fiber drum



The **Top Rim Clamp** grips the upper rim of your drum to prevent it from slipping through the drum holder. Use to handle a 55-gallon rimmed plastic or fiber drum. To handle a 55-gallon plastic drum with top rim, you must install either the Bracket Assembly or the Top Rim Clamp.

Part # 4560-P Rim Clamp Assembly.

Part # 4560M-P Spark Resistant Rim Clamp Assembly.

Diameter Adaptors for smaller diameter drum



Diameter Adaptors insert into the drum holder to handle your smaller drum. Select the correct size Diameter Adaptor for each drum (side 2). Spark resistant and stainless steel Diameter Adaptors are also available.



We recommend **Option # 3900i-P** MORStop Tilt-Brake factory installed on your Kontrol-Karrier to automatically hold the drum tilt angle.



Part # 3900-P MORStop Tilt-Brake Kit for field installation.

Option X01-185 Hand Crank with MORStop Tilt-Brake.



Option X02-185 Hand Crank.

Option X03-185 16" Hand Wheel.

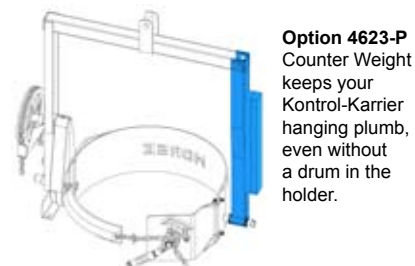

Option 4623-P Counter Weight keeps your Kontrol-Karrier hanging plumb, even without a drum in the holder.

Diameter Adaptors

Diameter Adaptors allow your Kontrol-Karrier to handle a smaller drum. Simply place the correct size Diameter Adaptor into the drum holder. When you complete dispensing from your smaller drum, simply lift the Diameter Adaptor out of the drum holder to return to handling a 55-gallon drum.

Diameter Adaptors for 17.5" diameter and smaller drums have brackets at top and bottom of the drum. They adjust to securely hold a drum up to 38" tall.

Spark resistant and stainless steel Diameter Adaptors are available for the same diameter ranges.



Model 55/30-19

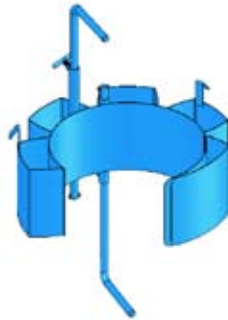

Model 55/30-17.5

DIAMETER ADAPTORS				
DIAMETER ADAPTORS	SPARK RESISTANT DIAMETER ADAPTORS	STAINLESS STEEL DIAMETER ADAPTORS	FITS DIAMETER	SHIP WEIGHT
55/30-20.5	55/30M-20.5	55/30SS-20.5	20" to 20.5"	23 Lb.
55/30-19	55/30M-19	55/30SS-19	18.5" to 19"	24 Lb.
55/30-17.5	55/30M-17.5	55/30SS-17.5	17" to 17.5"	35 Lb.
55/30-16	55/30M-16	55/30SS-16	15.5" to 16"	35 Lb.
55/30-14.5	55/30M-14.5	55/30SS-14.5	14" to 14.5"	36 Lb.

Dimensions

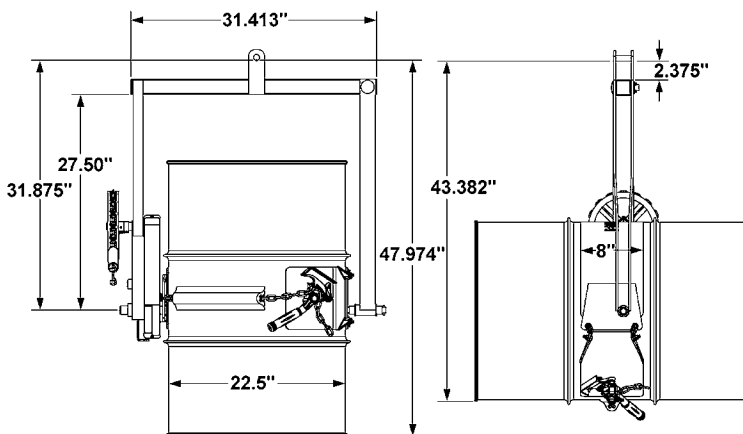

NOTE: Standard loop of pull chain extends approximately six feet below the chain wheel. Custom lengths are available.

Steps For Use of Morse Kontrol-Karriers

1. Attach the Kontrol-Karrier to your hoist hook, then move to your upright drum.
2. Mate the Kontrol-Karrier's drum holder to the middle of your drum.
3. Secure drum holder to your drum between drum ribs... no tools are needed. To secure drum, drape the cinch chain with flexible chain cover across the front of the drum, insert one link into the slot on the ratchet handle, and turn the ratchet handle clockwise to tighten the cinch chain around the drum.
4. Tighten the Top Rim Clamp or adjust the Bracket Assembly height, if your Kontrol-Karrier is so equipped.
5. Lift the Kontrol-Karrier and secured drum, with your hoist or crane.
6. To control turning of your drum, pull down on one side of the pull chain loop while letting out the other.

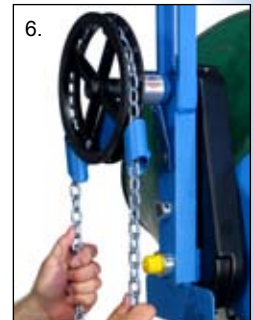

7. To remove a drum from your Kontrol-Karrier, turn the ratchet handle clockwise to relieve pressure on the ratchet teeth, lift the pawl handle to release teeth engagement, then rotate the ratchet handle counter clockwise to loosen the chain and allow its removal from the slot on the ratchet handle.

Please contact your Morse dealer