

Controlled Drum Pouring with Your Hoist or Crane

KONTROL- KARRIERS with POWER-TILT

- Attach to your monorail, crane, or chain block
- Quick, sure below hook drum handling by one person
- Save time, reduce waste, improve productivity
- Efficient controlled high level pouring
- Options to handle almost any drum
- Capacity: **1500 Lb. (682 kg) for a full drum**
800 Lb. (364 kg) for a half-full drum *

Morse power-tilt Kontrol-Karriers for below-hook applications provide controlled drum tilt of 360° in both directions. It takes just 15 seconds to fully invert your drum from upright. The controls allow you to manipulate drum tilting from below, with the drum raised.

All Morse below-hook drum lifters comply with ANSI/ASME B30.20 standard for mechanical, below-the-hook lifting devices as it applies to rated load markings and unit identification, minimum design safety factor of 3, based on yield strength, for load bearing structural components. Welding performed by certified welders who have passed the ANSI/AWS D1.1 welding qualification test

Drum Holders

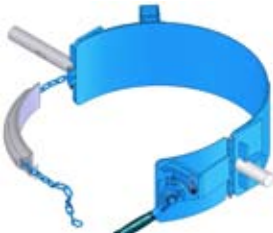

Cinch Chain and Ratchet



3-Piece Drum Holder

The cinch chain and ratchet drum holder is sized to handle your 22.5" (57 cm) diameter 55-gallon (208 liter) steel drum, and is equipped with a flexible cinch chain cover to help grip and protect the sidewall of your drum. Use the cinch chain and ratchet mechanism to secure around the drum. It accepts options to handle various smaller diameter drums or your 55-gallon plastic drum (see side 2).

Models with the 3-Piece Drum Holder secure your drum with three hinged metal bands and a toggle clamp in the front. The 3-Piece Drum Holder is sized for a standard 55-gallon (208 liter) 22.5" (57 cm) diameter steel drum. These models accept a Diameter Adaptor for a 19" (48 cm) diameter 30-gallon (114 liter) steel drum, part # 55/30-19GR.



Model 195A-A

Air powered models have a 3-position control valve on a 12 foot (3.6 m) coiled hose.

The air motor requires air supply at 40 psi at a rate of 40 scfm.



Model 195A-1-115

AC powered models have 2-button pendant on 7 foot (2.1 m) cord.

Power Tilt Kontrol-Karriers

Ship dimensions:

L51" W27" H45"
(130 x 69 x 114 cm)

Freight class 77.5

Ship fully assembled packaged in wooden crate.

Steps for use of 195 Series Kontrol-Karriers

1. Attach your hoist hook to the lifting point. Lift and move the Kontrol-Karrier to your upright drum.
2. Mate your Kontrol-Karrier's drum holder to the middle of the drum and secure the drum between the drum ribs... no tools are needed
3. Use the controls to turn the drum. The Kontrol-Karrier provides 360° control of drum tilt in either direction, even while drum is hoisted above your reach.

MODEL #	DESCRIPTION	Drum Holder	Ship Weight
195A-1-115	AC Power-Tilt Kontrol-Karrier, 1/3 HP/1 phase/115V motor	Cinch Chain & Ratchet	467 Lb. (212 kg)
195A-1-220-50	AC Power-Tilt Kontrol-Karrier, 1/3 HP/1 phase/220V 50Hz motor	Cinch Chain & Ratchet	467 Lb. (212 kg)
195A-3-230	AC Power-Tilt Kontrol-Karrier, 1/3 HP/3 phase/230V motor	Cinch Chain & Ratchet	467 Lb. (212 kg)
195A-3-460	AC Power-Tilt Kontrol-Karrier, 1/3 HP/3 phase/460V motor	Cinch Chain & Ratchet	467 Lb. (212 kg)
195A-A	Air motor Power-Tilt Kontrol-Karrier	Cinch Chain & Ratchet	453 Lb. (206 kg)
195AM-A	Air motor Power-Tilt Kontrol-Karrier, spark resistant parts	Cinch Chain & Ratchet	460 Lb. (209 kg)
195G-1-115	AC Power-Tilt Kontrol-Karrier, 1/3 HP/1 phase/115V motor	3-Piece Drum Holder	487 Lb. (221 kg)
195G-3-230	AC Power-Tilt Kontrol-Karrier, 1/3 HP/3 phase/230V motor	3-Piece Drum Holder	487 Lb. (221 kg)
195G-3-460	AC Power-Tilt Kontrol-Karrier, 1/3 HP/3 phase/460V motor	3-Piece Drum Holder	487 Lb. (221 kg)
195G-A	Air motor Power-Tilt Kontrol-Karrier	3-Piece Drum Holder	480 Lb. (218 kg)

* Half-full rating is an indication of capacity for tilting an unbalanced, bottom-heavy drum. A partially full drum with unbalanced and shifting load is harder to tilt than full drum.

Dimensions

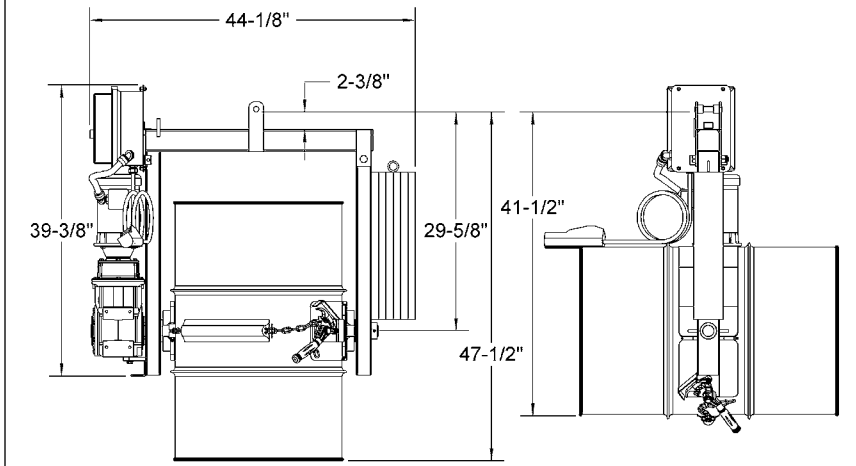

Bracket Assembly Option

Install the optional Bracket Assembly (part # 4556-P) to prevent your 55-gallon (208 liter) plastic drum from slipping through the drum holder. It is also recommended to more securely hold your fiber drum.

With the Bracket Assembly in place you can handle a drum from 31" to 37" (78.7 to 94 cm) tall, and it still accepts Diameter Adaptors for your smaller drums. Note: Diameter Adaptors for 14" to 17.5" (35.6 to 44.5 cm) diameter have integrated brackets, therefore do not require the Bracket Assembly.

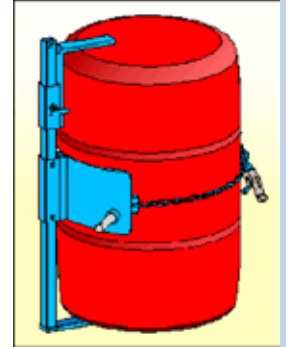

MADE
IN
USA

Optional Diameter Adaptors for Smaller Drums

Use correct size Diameter Adaptor for each smaller size drum.

Simply insert the Diameter Adaptor into the drum holder to handle your smaller drum with the same unit. To return to handling a 55-gallon (208 liter) drum, simply lift the Diameter Adaptor out of the drum holder.

Example: Use model 195A-1-115 with model 55/30-19 Diameter Adaptor inserted to lift and dispense your 19" (48.3 cm) diameter drum.



Diameter Adaptors for 14" to 17.5" (35.6 to 44.5 cm) diameters have integrated hold-down brackets at top and bottom of the drum. The hold-downs adjust for a drum up to 38" (96.5 cm) tall.

Spark resistant Diameter Adaptors are made of monel. Diameter Adaptors made of type 304 stainless steel are also available.

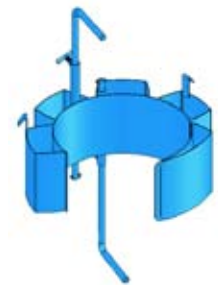

Model 55/30-16



Model 195A-1-115 shown with Model 55/30-19 Diameter Adaptor and Bracket Assembly option



Model 55/30-19

Diameter Adaptors from 18.5" to 22" (47 to 55.9 cm) lack the hold-down brackets. The optional Bracket Assembly (part # 4556-P) is required for handling your plastic drum, and recommended to more securely hold your fiber drum.

Model 55/30-19GR Diameter Adaptor only fits models with 3-Piece Drum Holder. It quickly and easily inserts to handle your 19" (48.3 cm) diameter 30-gallon (114 liter) steel drum. Then simply lift it back out to go back to handling a 55-gallon (208 liter) steel drum.



Model 55/30-19GR

Diameter Adaptors

Steel Adaptors	Stainless Steel Adaptors	Spark Resistant Adaptors	Fit Diameter *
55/30-22	55/30SS-22	55/30M-22	21.5" to 22" (54.6 to 55.9 cm)
55/30-20.5	55/30SS-20.5	55/30M-20.5	20" to 20.5" (50.8 to 52.1 cm)
55/30-19	55/30SS-19	55/30M-19	18.5" to 19" (47 to 48.3 cm)
55/30-17.5	55/30SS-17.5	55/30M-17.5	17" to 17.5" (43.2 to 44.5 cm)
55/30-16	55/30SS-16	55/30M-16	15.5" to 16" (39.4 to 40.6 cm)
55/30-14.5	55/30SS-14.5	55/30M-14.5	14" to 14.5" (35.6 to 36.8 cm)
55/30-19GR **	-	-	19" (48.3 cm)

* Measure circumference half way down your drum. Then divide by pi (3.14).

** Only fits models with 3-piece drum holder - e.g. Model 195G

Please contact your Morse dealer