

Lift, Transport and Pour Drums with Your Forklift

Model 285A-BP Power-Tilt Forklift-Karrier

- Add drum handling to your fork truck
- Raise drum and control pouring
- Video at: www.morsemfgco.com
- Attach and detach from forklift quickly
- No tools or truck modification needed
- No electric or hydraulic connections
- Eliminate backbreaking labor and dangerous, makeshift methods
- Fully invert a drum in less than 15 seconds

Options to Handle Almost Any Drum

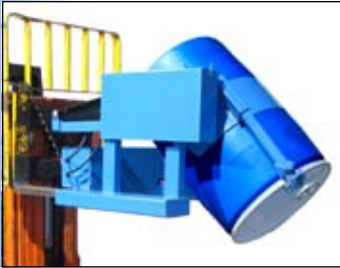

Top Rim Clamp

The **Top Rim Clamp** grips the upper rim of your drum to prevent it from slipping through the drum holder. Use to handle a 55-gallon rimmed plastic or fiber drum. To handle a 55-gallon plastic drum with top rim, you must install either the Bracket Assembly or the Top Rim Clamp.



Part # 4560-P
Rim Clamp Assembly.



Bracket Assembly

The **Bracket Assembly** provides a brace at top and bottom of your drum to prevent it from slipping lengthways through the drum holder. The Bracket Assembly is required to handle a rimless plastic drum, and recommended to more securely handle a fiber drum. It adjusts for 31" to 39" tall drum.

Part # 4556-P Bracket Assembly.

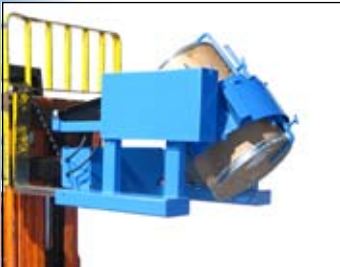

Diameter Adaptors

For a smaller diameter drum, Diameter Adaptors fit inside the drum holder. They install easily without tools and are quickly removed.

Diameter Adaptors for 17.5" diameter or smaller have brackets at top and bottom of the drum. They adjust for a drum up to 38" tall. Spark resistant and stainless steel Diameter Adaptors are also available.

Quickly insert the correct size Diameter Adaptor into the drum holder. Simply remove it to return to handling a 55-gallon drum.



DIAMETER ADAPTORS		
MODEL #	FITS DIAMETER	SHIP WEIGHT
55/30-14.5	14" to 14.5"	36 Lb.
55/30-16	15.5" to 16"	35 Lb.
55/30-17.5	17" to 17.5"	35 Lb.
55/30-19	18.5" to 19"	24 Lb.
55/30-20.5	20" to 20.5"	23 Lb.
55/30-22	21.5" to 22"	14 Lb.



Battery Powered Drum Tilt Control

Model 285A-BP provides 12V battery-powered drum tilt with controls on a 10' cord, so you can control drum pouring with pushbutton ease while in your truck. Fully invert your drum to completely empty the contents. Drum tilt may be started, stopped or reversed at any point in the 180° range.

Model 285A-BP Forklift-Karrier has its own battery. No power connection or truck modification is required. A separate charger is included.

Capacity: 1,200 Lb. full-drum

600 Lb. Half-full capacity*

Ship dimensions: L 39" W 41" H 28"

Ship weight: 395 Lb.

Forklift-Karrier Dimensions

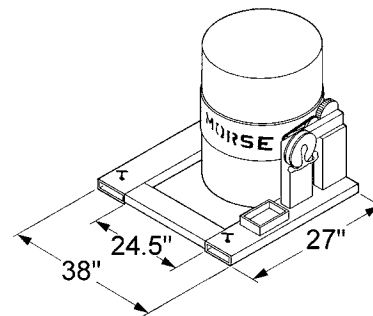

Fork pocket openings are 6.5" wide x 2.5" high.

Fork pockets are 26.5" deep.

Inside width between forks must be at least 24.5".

Shipped assembled in durable carton.

Custom versions can be made for non-standard forks.

* Half-full rating is an indication of capacity for tilting an unbalanced, bottom-heavy drum. A partially full drum with unbalanced and shifting load is harder to tilt than a full drum.